

PB Series

PB IRONERS



THE EXCELLENCE IS IN THE DETAIL

GIRBAU

PB IRONERS

POWERING DETAILS

PB/PBP5119
PB/PBP5125
PB/PBP5132



PB3215
PB3221



THE EXCELLENCE IS IN THE DETAIL

Let your customers experience excellence in all its details and enjoy the benefits of professional ironing in your business.

- +** **QUALITY**
Girbau's exclusive kinematic strap tension system and Care Touch Roll ensure a quality finish.
- +** **PRODUCTIVITY**
The efficiency of the PB ironers makes it possible to process garments directly from HS Series high speed washing machines, while guiding the operator during the ironing process.
- +** **SAFETY**
The hand-guard protection system ensures operator safety. A double sensor monitors the active and rest position with an initial check at each start-up.
- G** **EXPERIENCE**
We pass on the know-how we acquire to our clients when defining the laundry project suited to their needs, and with the continuous advice and training of the Girbau Laundry Tips service. This is how we achieve Easy & Best Solutions.

ERGONOMICS

The position and width of the feeding belt where the linen is positioned, and good foot access under the belt make for effortless ironing operations, allowing the operator to maintain a comfortable and natural position while working, and thus avoid unnecessary effort.

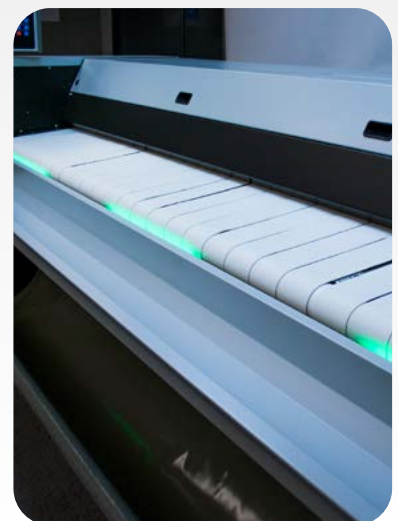

WE TAKE GREAT CARE OVER THE DETAILS

Feel the crisp freshly ironed sheets on your skin, lay in bed wrapped in a comfy quilt, set out a napkin and observe the geometry of its folds, or see how a perfect tablecloth makes a dinner much more special. Can anyone doubt the power of details? Does anyone doubt how every detail in each article of linen can become a sensation?

Girbau's ironers seduce with their details, with the finish they give to the linen. This is why we design our equipment down to the last detail, as befits equipment destined to become every laundry's badge of honour.

Because we want our customers to feel the essence of the detail.

GIRBAU

FLEXIBILITY

The main objective of the PB Series ironers is to aid the ironing process in laundries where space and production make this a critical process. The flexibility of this product reveals itself in its multiple configurations and heating options.

HEATING OPTIONS

ELECTRIC

It is not synonymous with high consumption, and is essential for laundries where there are no other energy supplies.

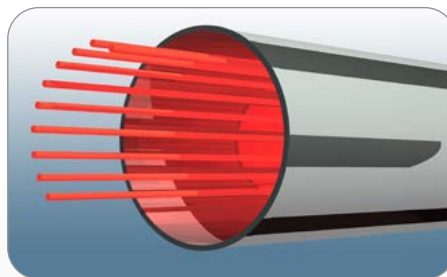

STEAM

Steam continues to be a requirement for many laundries and is a system that delivers high performance, which is why it is also available for the PB Series.

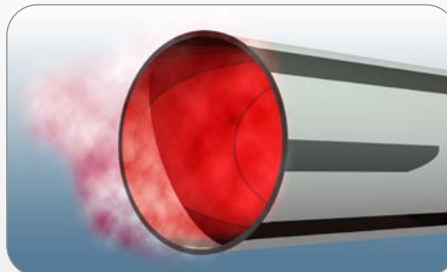

GAS

A clean and highly efficient system that requires the minimum of maintenance. Two types of burner.

Atmospheric, standard burner.

Radiant, an enriched mixture that provides greater power and efficiency.

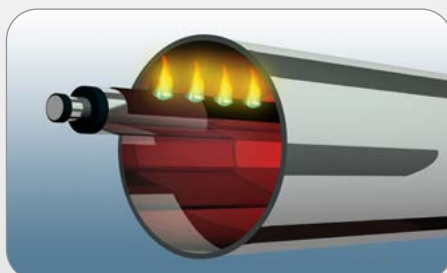

SETTINGS

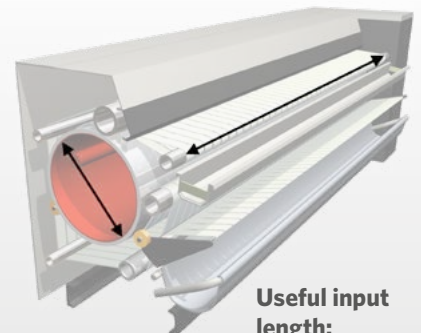

Roll diameter:	Useful input length:
320mm	1,500mm
510mm	1,900mm
	2,100mm
	2,500mm
	3,200mm

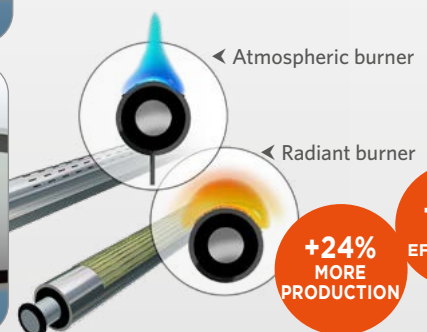

**+24%
MORE
PRODUCTION**

**WITH
+8%
MORE
EFFICIENCY**



EVEN IRONING

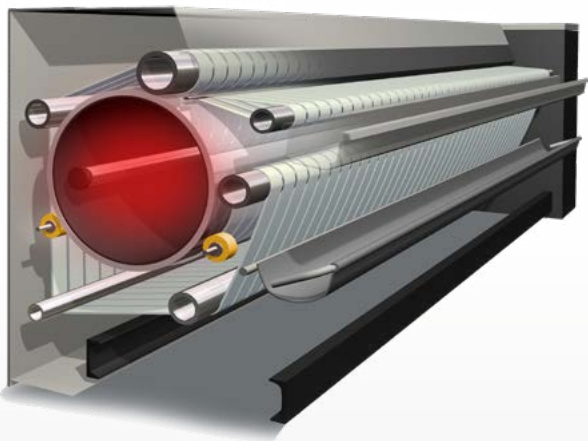

A PATENT THAT MAKES THE DIFFERENCE

The **Kinematic tensioning system** patented by Girbau is one of the key factors in explaining the quality of the finish obtained in PB ironers.

This system is based on a permanent balance of tensions and weights between different rolls that achieves permanent tensioning of the straps. The system uses the movement of the straps along the rolls to rebalance these in order to maintain an even tension and achieve a professional finish.



CARE TOUCH ROLL

A roll with a chrome surface coating that achieves excellent ironing quality, extends the life of the fabric, and is also highly resistant to corrosion even after periods of inactivity.

The **angle of contact** of the linen with the roll is **270°**, making it possible to work at high speed (up to 11 and 15 m/min, depending on the model).





DESIGNED TO LAST

+ **HARD-WEARING**
The ironer's safety covers are metal, and therefore more hard-wearing. The roll is made of machined steel with mirror polishing and chrome plating. The bearings are lubricated with grease that is permanently temperature resistant.

+ **RELIABILITY**
The gear motor-inverter assembly provides a secure transmission, more speed ranges and less wear and tear.

+ **ACCESSIBILITY** All the machine's parts are designed to be extremely accessible and easy to maintain. The lint filter is easy to clean. The metal side covers make for easy maintenance operations.

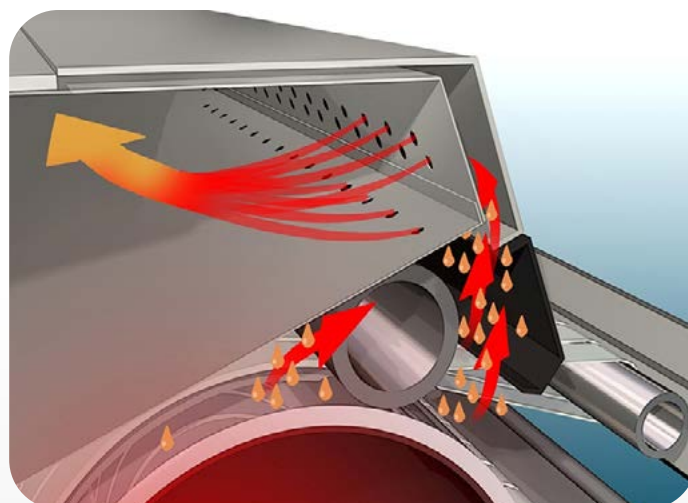

▲ Moisture extracted by suction

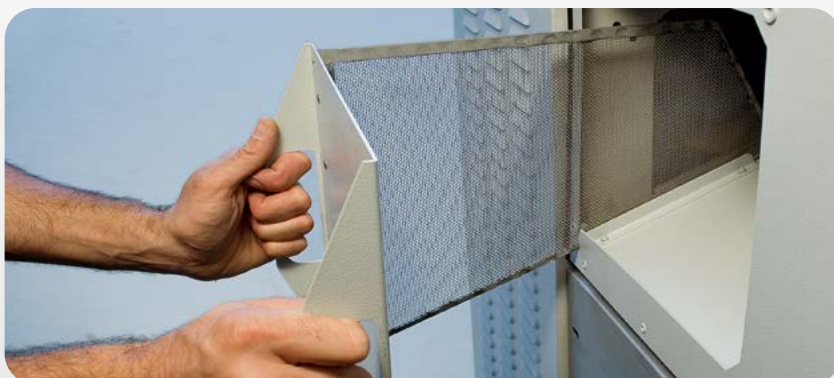

▲ Filter



▲ Safety covers



FEEDING AND FOLDING



FEEDING

With the PB series, 1, 2 or 4 lanes can be fed simultaneously, for all kinds of linen (sheets, table linen and small items such as napkins and pillowcases).

FOLDING

The **PBP models** incorporate a **1-lane folder** using a photocell system that calculates the total length of the item and adjusts the primary folding.

In **automatic mode** it adapts to all kinds of article without needing to change the program or interrupt the process.

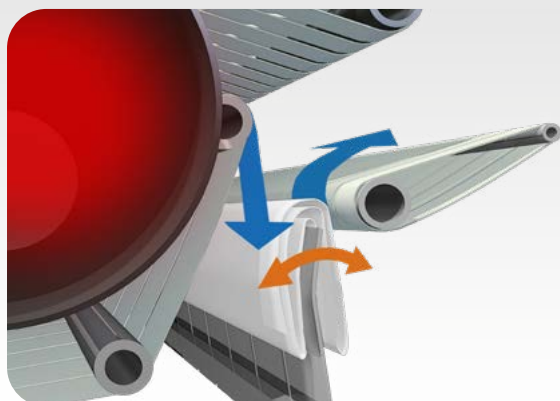
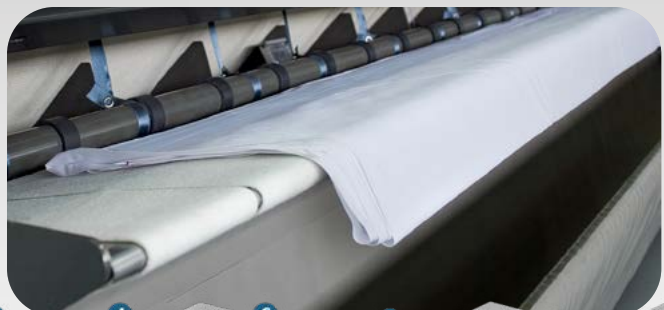

▲ Up to 14 primary folds.

In **manual mode** the operator sets the length of the article and the controller determines the number of folds and their length. In **advanced mode** the operator sets the length of the article and selects the number of folds desired.

ASSISTING IRONING TO IMPROVE PRODUCTIVITY

Understanding ironing as a process and not as a simple activity is what makes PB ironers different. We have analysed every step of the process, and for each step we have looked for mechanisms that help to make the ironing operation more cost-effective, productive, comfortable and safe.

In PB ironers you will find the best assistant for improving the productivity of your laundry.



IRONING ENHANCEMENT

CONTROL INTELI CONCEPT

Programming and controlling the PB Series ironer is straightforward and intuitive. A system of easily understood icons indicates the program, the real and the programmed temperature, the speed and the length of the article, in addition to advising the operator on the most optimum and productive operating mode.



◀ PB32



▼ PB51



AUTOSPEED

The Autospeed system automatically adjusts the ironing speed depending on the type of linen and the degree of dampness. With Autospeed it is possible to maintain an even and stable temperature. The sensors capture precise and reliable information.



OPTIFEED

The control display indicates the feeding area with the highest temperature in real-time, in order to take the fullest advantage of the heat energy and increase productivity. The system is designed to guide the operator during the ironing process, and adapts to the type of garment and conditions.

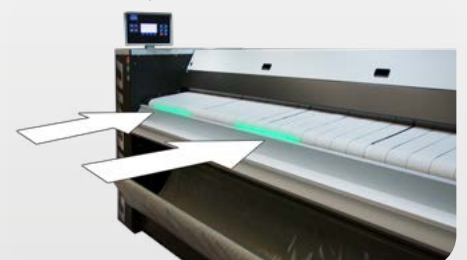
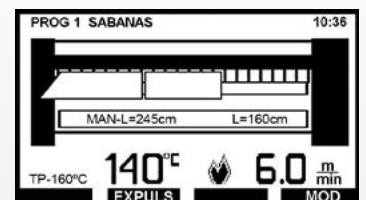



Girbau is a multi-national corporation that has cemented its position as one of the global leading groups in the manufacture of innovative solutions for the world of laundry. The goal of Girbau is to create maximum value for its customers, supporting them in their professional growth. The Girbau community supplies simple, dependable solutions that offer its clients profitability, innovation and sustainability.

With more than 60 years of experience as a manufacturer of washing and drying equipment, Girbau provides the most comprehensive offering of commercial, industrial, and vended laundry solutions in the world to meet your individual productivity and efficiency needs.

We want to provide the service and community you need to make your business special. That takes commitment beyond selling machines, and we're willing to walk the extra mile. And beyond all that, we want to help you care for the environment and innovate for the next generation.

These are tall orders, but Girbau can fill them with your help. Help us take laundry beyond laundry. Get in touch today!



The future is now

GIRBAU.COM

